

SECTION DMS

DRIVE MODE SYSTEM

A
B
C
D
E
F
G
H
I
J
K
L
M
N
P

CONTENTS

Infiniti InTuition		Log-in Function	16
PRECAUTION	2	BASIC INSPECTION	17
PRECAUTIONS	2	DIAGNOSIS AND REPAIR WORK FLOW	17
Precautions for Removing Battery Terminal	2	INFINITI DRIVE MODE SELECTOR	17
Precaution for Harness Repair	2	Infiniti Drive Mode Selector : Work Flow	17
SYSTEM DESCRIPTION	3	LOG-IN FUNCTION	18
COMPONENT PARTS	3	LOG-IN FUNCTION : Work Flow	19
Component Parts Location	3	DTC/CIRCUIT DIAGNOSIS	21
Drive Mode Select Switch	6	DRIVE MODE SELECT SWITCH CIRCUIT	21
SYSTEM	7	Diagnosis Procedure	21
INFINITI INTUITION	7	Component Inspection (Drive Mode Select Switch)	21
Infiniti InTuition : System Description	7	SYMPTOM DIAGNOSIS	23
INFINITI DRIVE MODE SELECTOR	7	USER RECOGNITION OF LOG-IN FUNCTION IS NOT PERFORMED	23
Infiniti Drive Mode Selector : System Description.....	7	Description	23
LOG-IN FUNCTION	9	Diagnosis Procedure	23
LOG-IN FUNCTION : System Description	9	NORMAL OPERATING CONDITION	24
INFORMATION DISPLAY (COMBINATION METER)	14	LOG-IN FUNCTION	24
INFORMATION DISPLAY (COMBINATION METER) : Warning/Indicator/Information	14	LOG-IN FUNCTION : Description	24
WARNING/INDICATOR/CHIME LIST	15	REMOVAL AND INSTALLATION	25
WARNING/INDICATOR/CHIME LIST : Warning/Indicator (On Information Display)	15	DRIVE MODE SELECT SWITCH	25
HANDLING PRECAUTION	16	Removal and Installation	25
Infiniti Drive Mode Selector	16		

DMS

< PRECAUTION >

PRECAUTION

PRECAUTIONS

Precautions for Removing Battery Terminal

INFOID:000000011551530

- When removing the 12V battery terminal, turn OFF the ignition switch and wait at least 30 seconds.

NOTE:

ECU may be active for several tens of seconds after the ignition switch is turned OFF. If the battery terminal is removed before ECU stops, then a DTC detection error or ECU data corruption may occur.

- For vehicles with the 2-batteries, be sure to connect the main battery and the sub battery before turning ON the ignition switch.

NOTE:

If the ignition switch is turned ON with any one of the terminals of main battery and sub battery disconnected, then DTC may be detected.

- After installing the 12V battery, always check "Self Diagnosis Result" of all ECUs and erase DTC.

NOTE:

The removal of 12V battery may cause a DTC detection error.

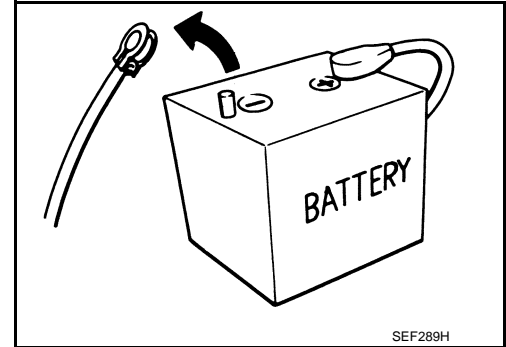

SEF289H

Precaution for Harness Repair

INFOID:000000011284375

- Solder the repair part, and wrap it with tape. [Twisted wire fray must be 110 mm (4.33 in) or less.]

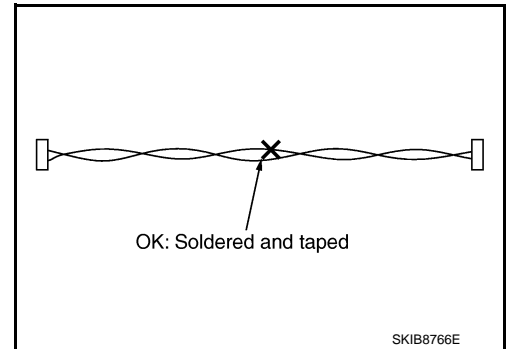

SKIB8766E

- Never bypass the repair point with wire. (If it is bypassed, the turn-out point cannot be separated and the twisted wire characteristics are lost.)

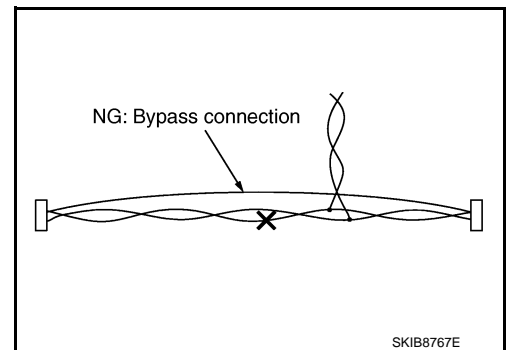

SKIB8767E

< SYSTEM DESCRIPTION >

SYSTEM DESCRIPTION

COMPONENT PARTS

Component Parts Location

INFOID:000000011284376

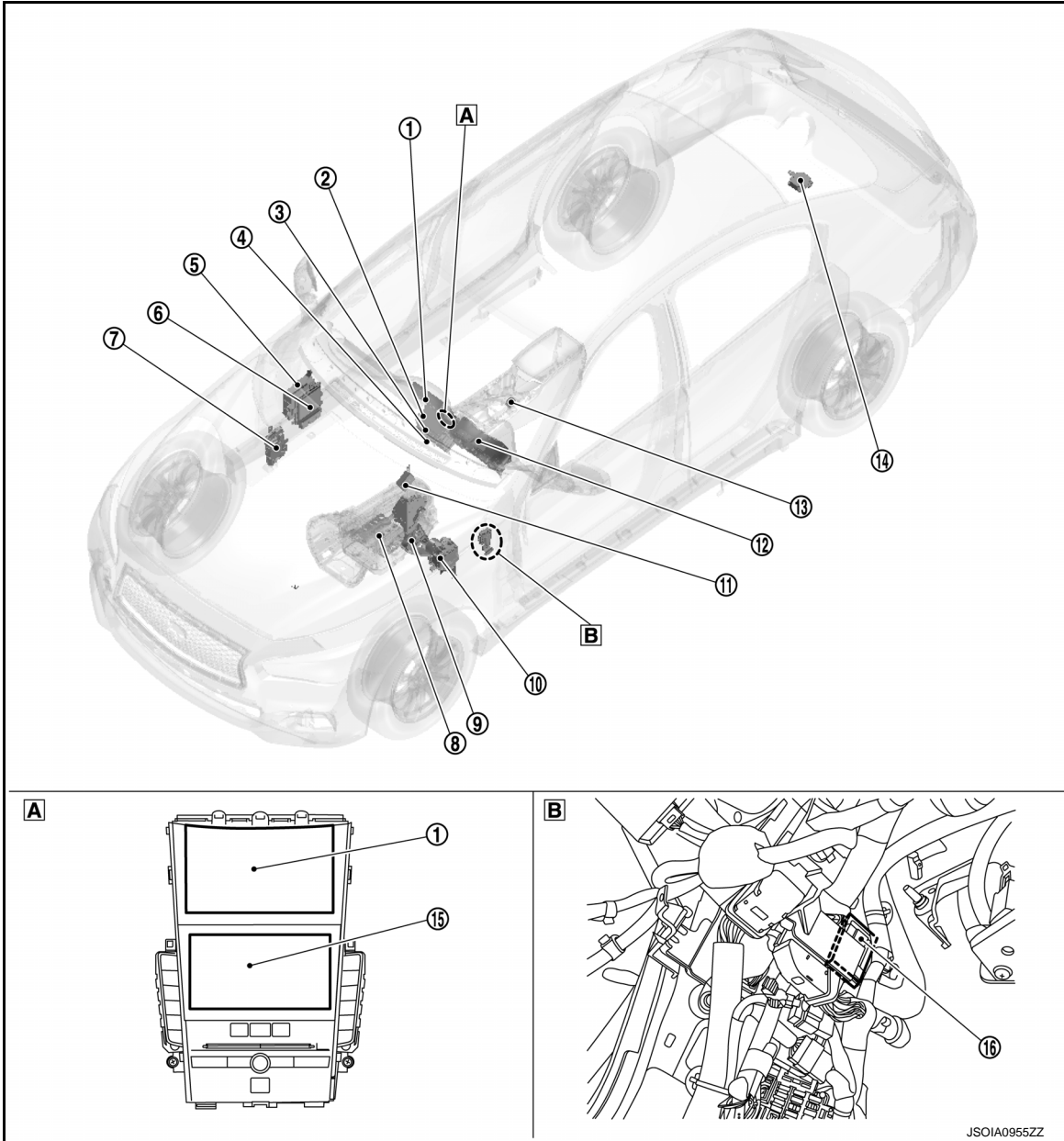

A Integral switch

B Inside of dash side finisher LH

A
B
C
D
E
F
G
H
I
J
K
L
M
N
P

DMS

COMPONENT PARTS

[Infiniti InTuition]

< SYSTEM DESCRIPTION >

No.	Part	Description
①	Display control unit	<ul style="list-style-type: none"> • Display control unit receives the following signal from integral switch. <ul style="list-style-type: none"> - Select signal • Display control unit transmits information of PERSONAL mode set by the driver to the chassis control module via the following signal. <ul style="list-style-type: none"> - Drive mode characteristics customizing signal • The display control unit transmits an user information signal to the following units: <ul style="list-style-type: none"> - Combination meter - A/C auto amp. - Driver seat control unit - ADAS control unit - Chassis control unit • The display control unit receives a key link signal and a log-in permit signal from chassis control module. • The display control unit receives a key ID signal from BCM.
②	A/C auto amp.	<ul style="list-style-type: none"> • The A/C auto amp. receives a key link signal and a log-in permit signal from chassis control module. • The A/C auto amp. receives a key ID signal from BCM. • The A/C auto amp. receives a user information signal from display control unit. Refer to HAC-5, "AUTOMATIC AIR CONDITIONING SYSTEM : Component Parts Location" for installation.
③	NAVI control unit	The NAVI control unit receives a user information signal from display control unit. Refer to AV-14, "Component Parts Location" for installation.
④	AV control unit	The AV control unit receives a user information signal from display control unit. Refer to AV-14, "Component Parts Location" for installation.
⑤	Steering force control module	<ul style="list-style-type: none"> • Steering force control module receives the following signal from chassis control module. <ul style="list-style-type: none"> - Drive mode signal • Steering force control module controls the steering effort and response according to the received signal. Refer to STC-36, "Component Parts Location" for installation.
⑥	ECM	<ul style="list-style-type: none"> • ECM receives the following signal from TCM. <ul style="list-style-type: none"> - Drive mode signal • ECM controls throttle angle characteristics and torque according to the received signal and transmits the following signals to ADAS control unit. <ul style="list-style-type: none"> - ECO pedal reaction force control signal Refer to EC-17, "ENGINE CONTROL SYSTEM : Component Parts Location" for installation.
⑦	BCM	<ul style="list-style-type: none"> • The BCM transmits a key ID signal to the following units: <ul style="list-style-type: none"> - Combination meter - Display control unit - A/C auto amp. - Chassis control unit - Driver seat control unit - ADAS control unit Refer to BCS-4, "BODY CONTROL SYSTEM : Component Parts Location" for installation.
⑧	TCM	<ul style="list-style-type: none"> • TCM receives the following signal from chassis control module. <ul style="list-style-type: none"> - Drive mode signal • TCM selects a shift pattern according to the received signal and transmits the following signal to ECM and the ADAS control unit. <ul style="list-style-type: none"> - Drive mode signal Refer to TM-12, "A/T CONTROL SYSTEM : Component Parts Location" for installation.
⑨	Accelerator pedal actuator	<ul style="list-style-type: none"> • Accelerator pedal actuator receives the following signal from the ADAS control unit. <ul style="list-style-type: none"> - ECO pedal reaction force control signal • Accelerator pedal actuator exerts a feedback force on the accelerator pedal according to the received signal.

COMPONENT PARTS

[Infiniti InTuition]

< SYSTEM DESCRIPTION >

No.	Part	Description
⑩	ABS actuator and electric unit	<ul style="list-style-type: none"> • ABS actuator and electric unit receives the following signals from chassis control module. <ul style="list-style-type: none"> - Active trace control function control signal • ABS actuator and electric unit controls the active trace control function according to the received signal. <p>Refer to BRC-10. "Component Parts Location" for installation.</p>
⑪	Driver seat control unit	<ul style="list-style-type: none"> • The driver seat control unit receives a key link signal and a log-in permit signal from chassis control module. • The driver seat control unit receives a user information signal from display control unit. • The driver seat control unit receives a key ID signal from BCM. <p>Refer to SE-8. "POWER SEAT SYSTEM : Component Parts Location" for installation.</p>
⑫	Combination meter	<ul style="list-style-type: none"> • Combination meter receives the following signals from chassis control module. <ul style="list-style-type: none"> - Drive mode signal - Key link signal - Log-in permit signal • Combination meter displays the status of drive mode selected by the driver on the information display according to the received signal. • The combination meter receives a key ID signal from BCM. • The combination meter receives a user information signal from display control unit. <p>Refer to MWI-7. "METER SYSTEM : Component Parts Location" for installation.</p>
⑬	Drive mode select switch	<p>DMS-6. "Drive Mode Select Switch"</p>
⑭	ADAS control unit	<ul style="list-style-type: none"> • ADAS control unit receives the following signal from chassis control module. <ul style="list-style-type: none"> - Drive mode signal - Key link signal - Log-in permit signal • ADAS control unit controls accelerator reaction force of accelerator pedal actuator according to the received signal and transmits the following signals to accelerator pedal actuator. <ul style="list-style-type: none"> - ECO pedal reaction force control signal • The ADAS control unit receives a user information signal from display control unit. • The ADAS control unit receives a key ID signal from BCM. <p>Refer to CCS-7. "Component Parts Location" for installation.</p>
⑮	Integral switch (lower display)	<ul style="list-style-type: none"> • Integral switch (lower display) allows the driver to set a PERSONAL mode arbitrarily. • Integral switch (lower display) outputs the following signal (set by a driver) to the display control unit. <ul style="list-style-type: none"> - Select signal
⑯	Chassis control module	<ul style="list-style-type: none"> • Chassis control module receives the following signals from drive mode select switch and display control unit. <ul style="list-style-type: none"> From drive mode select switch <ul style="list-style-type: none"> - Up/down signal From display control unit <ul style="list-style-type: none"> - Drive mode characteristics customizing signal • Chassis control module identifies the drive mode selected by the driver according to the received signal and transmits the following signal to related control modules. <ul style="list-style-type: none"> - Drive mode signal • The chassis control module transmits a key link signal and a log-in permit signal to the following units: <ul style="list-style-type: none"> - Combination meter - Display control unit - A/C auto amp. - Driver seat control unit - ADAS control unit • The chassis control module receives a key ID signal from BCM. • The chassis control module receives a user information signal from display control unit. <p>Refer to DAS-394. "Component Parts Location" for installation.</p>

A
B
C
D
E
F
G
H
I
J
K
L
M
N
P

DMS

< SYSTEM DESCRIPTION >

Drive Mode Select Switch

INFOID:000000011284377

- Drive mode select switch is set on the upper part of the center console.

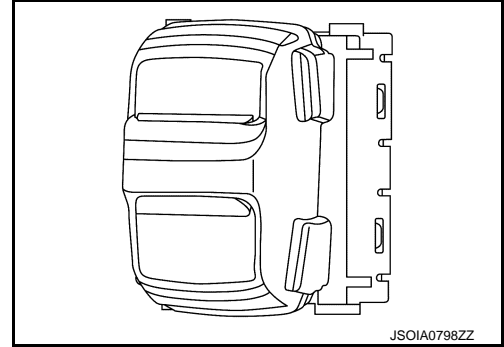

- The drive mode select switch is connected to the chassis control module and allows the driver to select a mode from PERSONAL, SPORT, STANDARD, ECO, and SNOW by the up/down operation.

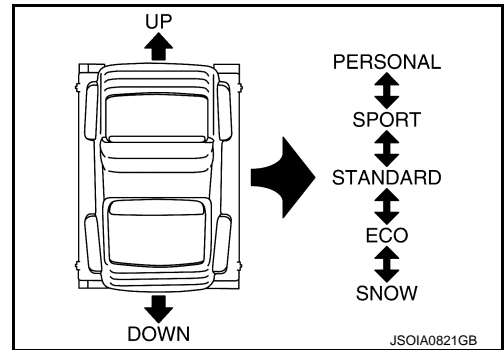

SYSTEM

Infiniti InTuition

Infiniti InTuition : System Description

INFOID:0000000011284378

Outline

- The adoption of Infiniti InTuition allows the customization of the vehicle to suit each driver and provides settings by driver.
- Infiniti InTuition consists of the following functions:
 - Infiniti drive mode selector function
 - Log-in function

For details of Infiniti Drive Mode selector functions, refer to [DMS-7, "Infiniti Drive Mode Selector : System Description"](#).

For details of log-in function functions, refer to [DMS-9, "LOG-IN FUNCTION : System Description"](#).

Infiniti Drive Mode Selector

Infiniti Drive Mode Selector : System Description

INFOID:0000000011284379

- All the vehicles are equipped with an Infiniti drive mode selector which switches a vehicle mode among PERSONAL, SPORT, STANDARD, ECO, and SNOW with the flick of a switch.
- The adoption of PERSONAL mode allows the driver to change the vehicle characteristics (arbitrarily) by using the integral switch (lower display).
- The Infiniti drive mode selector changes a vehicle mode to the powertrain, and chassis function.

SYSTEM DIAGRAM

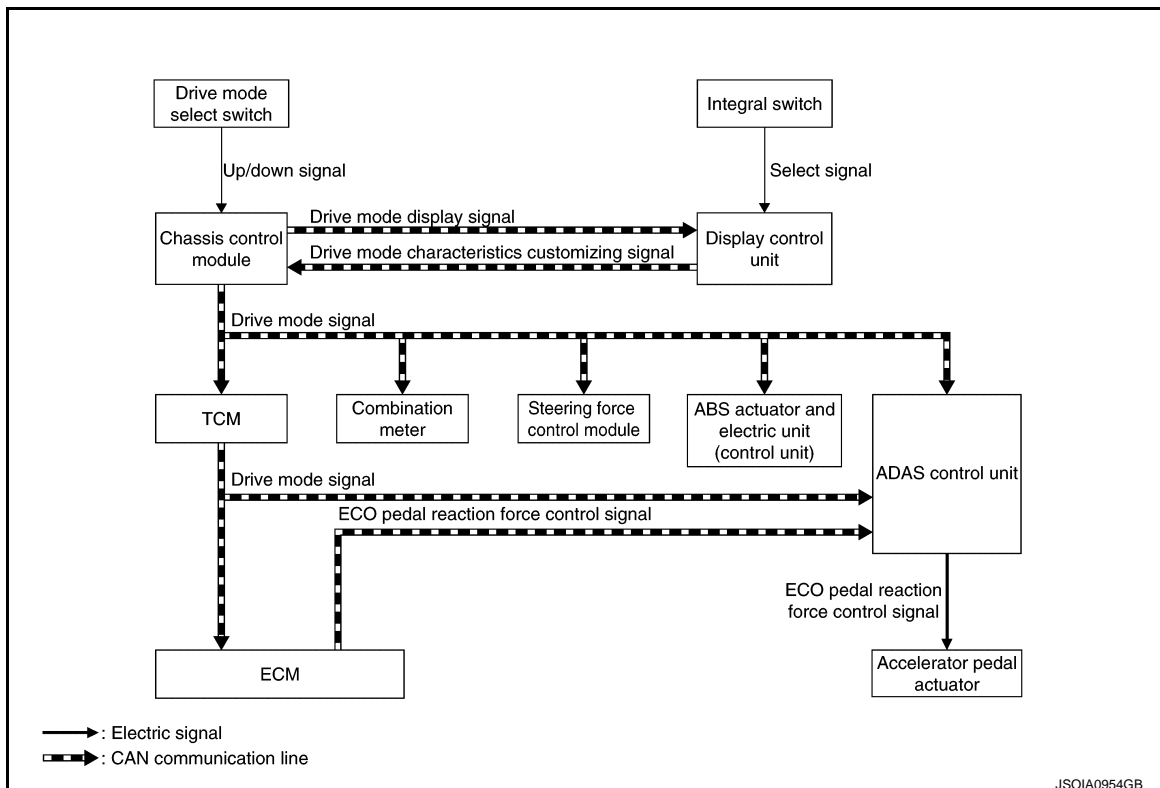

NOTE:

The steering force control module is applied to the direct adaptive steering system models only.

CONTROL DESCRIPTION

- The Infiniti Drive Mode Selector switches a vehicle mode with the flick of a switch (drive mode select switch) mounted on upper part of the center console and changes the control characteristics of the powertrain and chassis.
- When the ignition switch is turned ON from the OFF state, the Infiniti Drive Mode Selector starts in STANDARD mode regardless of drive mode during ignition switch ON.
- Active lane control operates in synchronization with the safety shield button by default.

A
B
C
D
E
F
G
H
I
J
K
L
M
N
P

DMS

SYSTEM

< SYSTEM DESCRIPTION >

[Infiniti InTuition]

Active lane control can be set to operate in synchronization with the safety shield button on the settings screen of Lane Assist in Driver Assistance.

- The operation of the integral switch allows the driver to set vehicle characteristics as in the following table. The driver can drive the vehicle with the vehicle characteristics set by selecting PERSONAL with the drive mode select switch.

Category	Item		Setting	
Active lane control ^{*1}	—		OFF	
			LOW	
			HIGH	
Personal mode	Engine-Transmission	SPORT		
		STANDARD		
		ECO		
		SNOW		
	Active Trace Control	ON		
		OFF		
	Steering ^{*2}	Setting	Effort	Response
		Standard	Middle	Middle
		Sports	Heavy	Quick
		Touring	Light	Casual
Sports light		Middle	Quick	

*1: Applied to the driver assistance system models only.

*2: Applied to the direct adaptive steering models only.

- The vehicle characteristics are controlled from the STANDARD mode to any mode listed below:

Select mode	Vehicle characteristics control
PERSONAL*	The vehicle characteristics can be set by the driver arbitrarily with the integral switch.
SPORT	The control characteristics of engine and steering function can be changed. This mode uses the high engine performance region and adds a crisp feel in steering wheel operation
ECO	ECO mode provides the features of assistance in the improvement of fuel economy such as smooth starts and stable cruising and facilities ECO driving.
SNOW	Changing the engine characteristics to aid driving in slick condition.

*: The setting is equivalent of STANDARD mode for Infinity Drive Mode Selector, based on the driver's settings.

- For relationship between drive mode and each control item, refer to the following table.

x: applicable

Items	Driving Mode				Control	Reference
	PERSONAL ^{*1}	SPORT	ECO	SNOW		
Active lane control function ^{*2}	x	x	x	x	On-off control of active lane control function.	DAS-548
Active trace control function	x				On-off control of active trace control function.	BRC-42
Engine (ECM)	x	x	x	x	<ul style="list-style-type: none"> Changes throttle angle characteristics and control torque. Controls the lighting of the ECO drive indicator lamp. (Only ECO turns ON.) 	EC-55
Transmission	x	x	x	x	Selects shift pattern.	TM-65
Steering ^{*3}	x	x			Controls effort and response of steering.	STC-41
ECO pedal ^{*4}	x		x		Controls feedback force of the accelerator pedal.	EC-55

SYSTEM

< SYSTEM DESCRIPTION >

[Infiniti InTuition]

Items	Driving Mode				Control	Reference
	PERSONAL*1	SPORT	ECO	SNOW		
Combination meter	×	×	×	×	Displays the selected drive mode.	BRC-45
Display control unit	×	×	×	×	Displays the selected drive mode and mode list as popup.	

*1: Depends on settings performed on the PERSONAL setting screen.

*2: Applied to the driver assistance system models only.

*3: Applied to the direct adaptive steering system models only.

*4: The application of the ECO pedal is only for vehicles with DCA (distance control assist).

LOG-IN FUNCTION

LOG-IN FUNCTION : System Description

INFOID:000000011284380

- The adoption of log-in function allows stored user-to-user settings to be called up through the recognition of the last user by the Intelligent Key.
- The log-in function identifies the driver through the use of the Intelligent Key and calls up driver-specific settings for items such as audio, navigation, seat position, and PERSONAL mode settings of the Infiniti Drive Mode Selector.
- For details of PERSONAL mode settings, refer to [DMS-7, "Infiniti Drive Mode Selector : System Description"](#).
- BCM receives a key ID signal from the Intelligent Key and transmits the signal to chassis control module, display control unit, combination meter, A/C auto amp, driver seat control unit, and ADAS control unit via CAN communication.
- Chassis control module transmits a key link signal to each unit via CAN communication.
- Display control unit transmits a user information signal to each unit via CAN communication and AV communication.
- Each unit calls up user information according to signals from BCM, chassis control module, and display control unit.
 - Driver seat control unit saves/reads set values such of seat position and mirror position.
 - A/C auto amp. saves/reads set values of temperature and DUAL settings.
 - Combination meter saves/reads set values of illumination control and language settings.
 - ADAS control unit saves/reads set values of warning sound and ON/OFF settings for each assist function.
 - Chassis control unit saves/reads settings of PERSONAL MODE characteristics of the Infiniti Drive Mode Selector.
 - Audio unit saves/reads set values of FM preset and balance.
- The number of registerable Intelligent Keys interlocked with user settings is 4.
- The driver's intelligent keys can be identified in the following order: Used for opening/closing by remote control → located close to the driver's door → identified at an engine start.

A
B
C
D
E
F
G
H
I
J
K
L
M
N
P

DMS

SYSTEM DIAGRAM

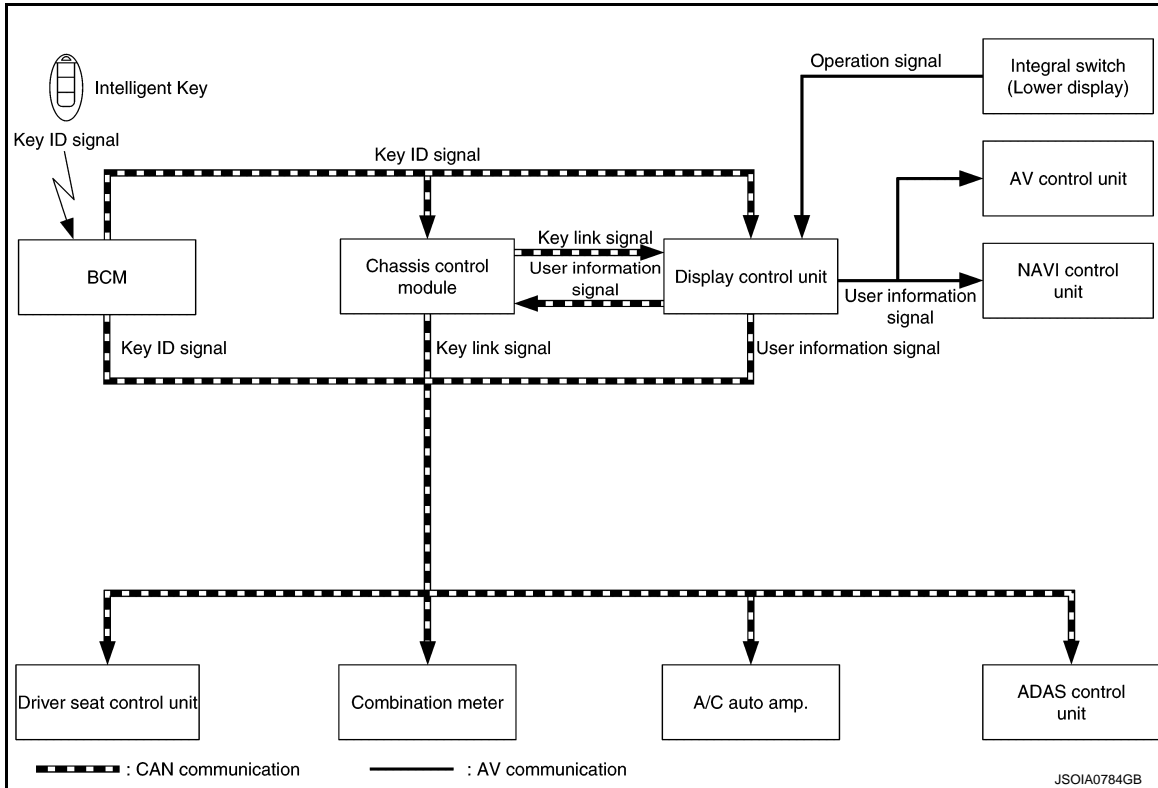

INPUT SIGNAL AND OUTOUT SIGNAL

Major signal transmission between each unit via communication lines is shown in the following table.

Component	Signal description
Chassis control module	<ul style="list-style-type: none"> • The chassis control module transmits a key link signal and a log-in permit signal to the following units: <ul style="list-style-type: none"> - Combination meter - Display control unit - A/C auto amp. - Driver seat control unit - ADAS control unit • The chassis control module receives a key ID signal from BCM. • The chassis control module receives a user information signal from display control unit.
BCM	<ul style="list-style-type: none"> • The BCM transmits a key ID signal to the following units: <ul style="list-style-type: none"> - Combination meter - Display control unit - A/C auto amp. - Chassis control unit - Driver seat control unit - ADAS control unit
Display control unit	<ul style="list-style-type: none"> • The display control unit transmits a user information signal to the following units: <ul style="list-style-type: none"> - Combination meter - A/C auto amp. - Driver seat control unit - ADAS control unit - Chassis control unit • The display control unit receives a key link signal and a log-in permit signal from chassis control module. • The display control unit receives a key ID signal from BCM.
Driver seat control unit	<ul style="list-style-type: none"> • The driver seat control unit receives a key link signal and a log-in permit signal from chassis control module. • The driver seat control unit receives a user information signal from display control unit. • The driver seat control unit receives a key ID signal from BCM.

SYSTEM

< SYSTEM DESCRIPTION >

[Infiniti InTuition]

Component	Signal description
Combination meter	<ul style="list-style-type: none"> • The combination meter receives a key link signal and a log-in permit signal from chassis control module. • The combination meter receives a key ID signal from BCM. • The combination meter receives a user information signal from display control unit.
A/C auto amp.	<ul style="list-style-type: none"> • The A/C auto amp. receives a key link signal and a log-in permit signal from chassis control module. • The A/C auto amp. receives a key ID signal from BCM. • The A/C auto amp. receives a user information signal from display control unit.
ADAS control unit	<ul style="list-style-type: none"> • The ADAS control unit receives a user information signal from display control unit. • The ADAS control unit receives a key ID signal from BCM.

USER REGISTRATION/EDIT

Registration

- The Intelligent Key used for the first time calls up all the settings for Guest.
- Once a driver performs user registration on the display control unit screen, the settings at this point are saved as the registered user information and linked with the Intelligent Key currently in use.
- If the Intelligent Key is used during the next drive, the registered user settings are applied.
If User A is registered while Key 1 is used, for example, the vehicle uses the settings of User A when entering the vehicle with Key 1 the next time.
- For the user information, the setting status when the key switch is turned OFF is saved.

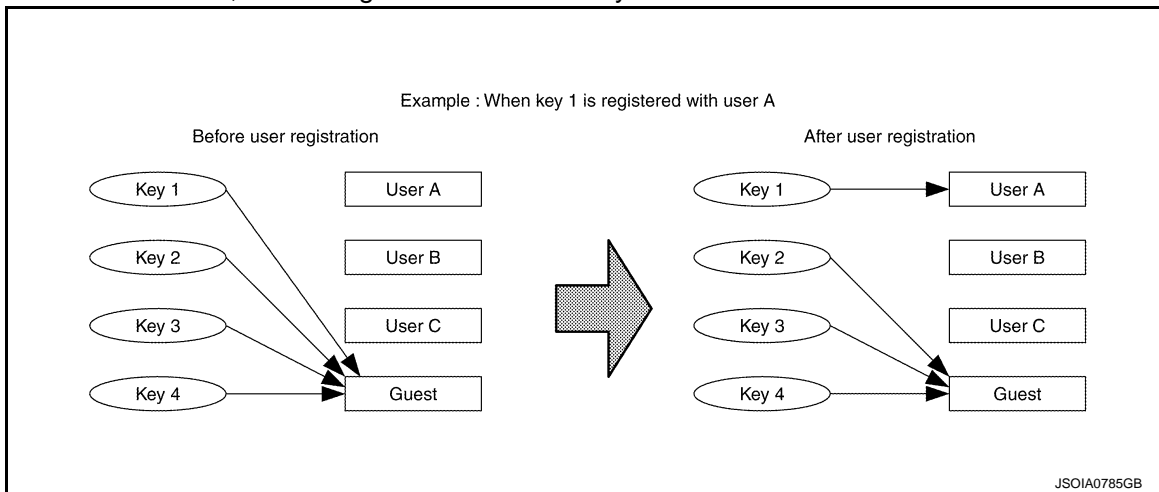

Change

- To change the current user settings to new user settings, the user settings can be changed in the display control unit.
- Once a user change operation is performed, the new user and the currently used Intelligent Key are linked.

NOTE:

When the user is changed, the display control unit screen enters a hatching state and prohibits the operation for approximately 2 seconds to secure the necessary period of time to change the user in each unit.

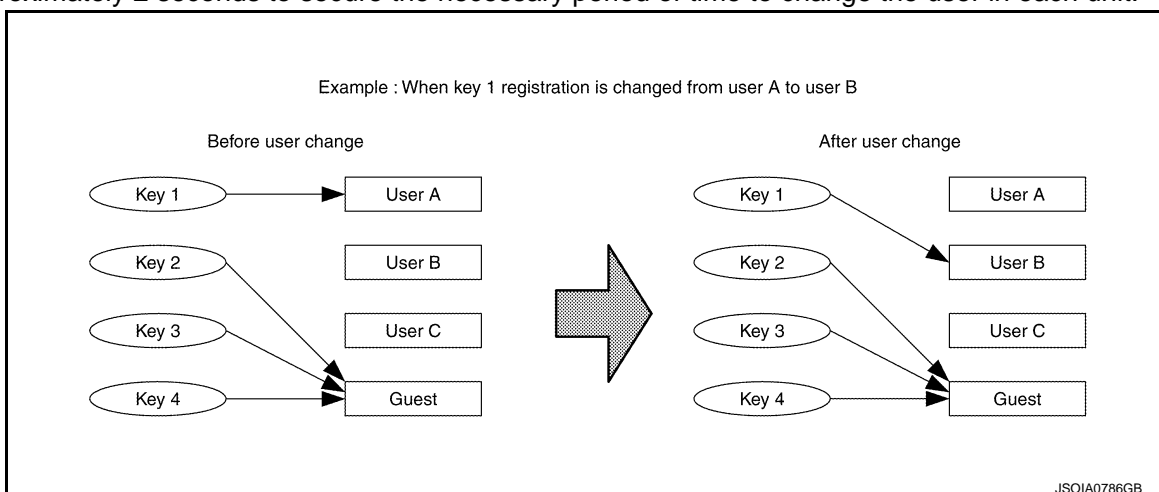

A
B
C
D
E
F
G
H
I
J
K
L
M
N

DMS

P

< SYSTEM DESCRIPTION >

Delete

- The registered user information can be deleted.
 - The Intelligent Key linked with the deleted user settings will call up the setting of Guest from the next time.
 - If the current user is deleted, the settings for Guest are called up.
 - The deleted user settings are changed* to the default settings.
- *: Since no default settings are provided for seat positions, mirror positions, and A/C settings, the old settings remain unchanged instead of returning to the default settings.

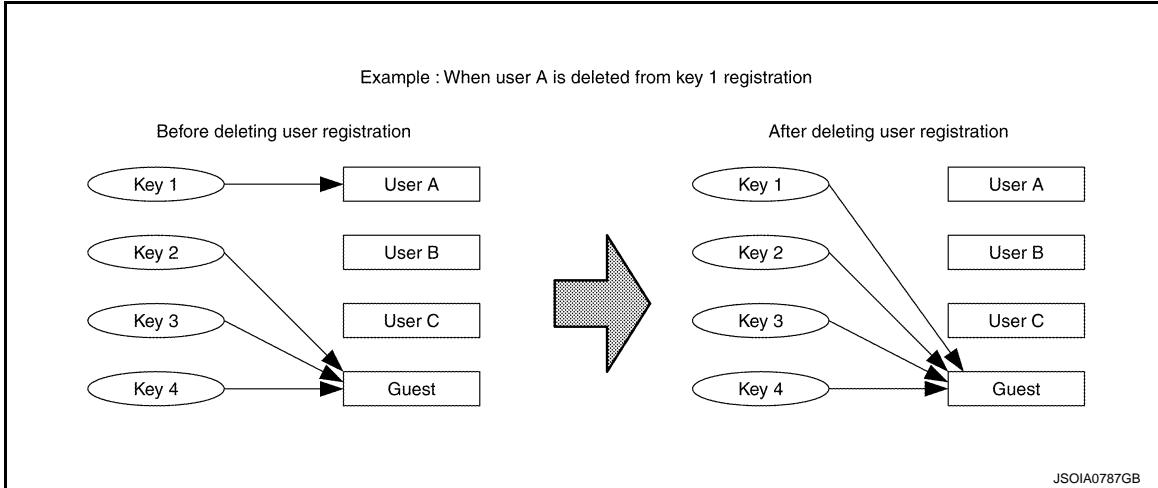

Copy

- The previously registered user settings can be copied to the settings of another user.

KEY-LINKED ON/OFF FUNCTION

ON/OFF can be set for the function for interlocking with Intelligent Key. Selecting OFF leads to the settings for Guest regardless of Intelligent Key type.

LIST OF LOG-IN FUNCTION SETTING ITEMS

Systems interlocked with the log-in function are as follows:

- Combination meter
- Air conditioner
- Automatic drive positioner
- Audio
- Display
- Navigation system
- Infiniti drive mode selector (PERSONAL mode)
- Driver Assistance

Refer to the table for details of items available for log-in settings.

Combination Meter

NOTE:

The following table includes inapplicable items depending on vehicle specifications. For applicable items, see the vehicle specifications.

Category	Item
Illumination and Contrast	Brightness Control
	Temperature unit
	Main Menu Selection
	Eco Mode Settings
Meter Screen Setting	Alarms
	Factory Reset
	Display Effect
	Language
	TPMS Unit
	Mileage Unit

SYSTEM

< SYSTEM DESCRIPTION >

[Infiniti InTuition]

Air Conditioner

NOTE:

The following table includes inapplicable items depending on vehicle specifications. For applicable items, see the vehicle specifications.

Category	Item
Switch Setting	AUTO Switch
	Temperature Setting
	Fan Speed
	Blow Port
	Air Flow
	Forest
A/C menu	A/C
	DUAL
Forest A/C Setting	Exhaust and Odors sensor Sensitivity

Automatic Drive Positioner

NOTE:

- Seat position set with the seat memory switch does not interlock with Intelligent Key.
- The following table includes inapplicable items depending on vehicle specifications. For applicable items, see the vehicle specifications.

Category	Item
Driver Sheet	Slide
	Reclining
	Front Seat Lifter
	Rear Seat Lifter
Steering	Tilt
	Telescopic
Outside Mirrors	Left Outside Mirror
	Right Outside Mirror

Audio/navigation

NOTE:

The following table includes inapplicable items depending on vehicle specifications. For applicable items, see the vehicle specifications.

Category	Item
Sound	Volume ^{*1,2}
	Bass/treble
	Fader/balance
	Speed sensitive volume system
	BOSE Centerpoint ^{*3}
	BOSE AUDIOPILOT ^{*3}
	Rear Sound Mode ^{*3}
	Driver's Audio Stage ^{*3}
Down Mix ^{*3}	

SYSTEM

< SYSTEM DESCRIPTION >

[Infiniti InTuition]

Category	Item
Radio	The most recently received frequency
	Traffic information frequency
	Traffic information (RDS)
	Radio Preset Frequency
Music Box	Registered songs/song information
Navigation	Route searching condition settings
System setting	Language setting
	Beep ON/OFF setting
	Guidance Voice ON/OFF setting
Voice recognition	Audio command learning result

*1: Without BOSE sound system

*2: Except for the volume other than that of audio (route guidance volume, telephone ring tone volume, etc.)

*3: With BOSE sound system

Infiniti Drive Mode Selector (PERSONAL Mode)

NOTE:

Infiniti drive mode selector returns to STANDARD every time the key switch is turned OFF. To call up user information of PERSONAL mode, PERSONAL mode must be selected after key ON.

For details of setting items for Infiniti Drive Mode Selector, refer to [DMS-7. "Infiniti Drive Mode Selector : System Description"](#).

Driver Assistance

NOTE:

The following table includes inapplicable items depending on vehicle specifications. For applicable items, see the vehicle specifications.

Category	Item
Driver Assistance - Forward Assist -	Distance Control Assist
Driver Assistance - Lane Assist -	Lane Departure Prevention
	Lane Departure Warning
Driver Assistance - Blind Spot Assist -	Blind Spot Intervention
	Blind Spot Warning
	Setting
Emergency Assist	Forward Emergency Braking

INFORMATION DISPLAY (COMBINATION METER)

INFORMATION DISPLAY (COMBINATION METER) : Warning/Indicator/Information

INFOID:000000011284381

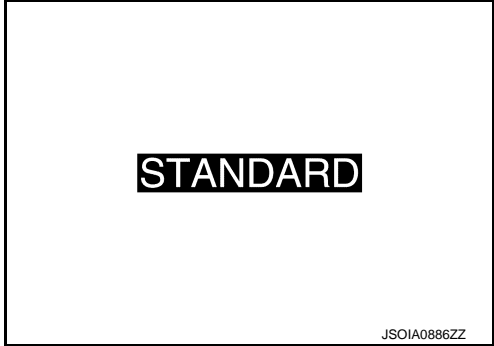
Item	Symbol	Function
Drive mode indicator	 <p style="text-align: right; font-size: small;">JSOIA0886ZZ</p>	<p>The following drive modes are indicated by operating drive mode select switch. Refer to DMS-7. "Infiniti Drive Mode Selector : System Description".</p> <ul style="list-style-type: none"> • PERSONAL • SPORT • STANDARD • ECO • SNOW

WARNING/INDICATOR/CHIME LIST

WARNING/INDICATOR/CHIME LIST : Warning/Indicator (On Information Display)

INFOID:000000011284382

Item	Reference
Drive mode indicator	Refer to DMS-14, "INFORMATION DISPLAY (COMBINATION METER) : Warning/Indicator/Information" .

A
B
C
D
E
F
G
H
I
J
K
L
M
N
P

DMS

HANDLING PRECAUTION

Infiniti Drive Mode Selector

INFOID:000000011284383

ENGINE OUTPUT CHARACTERISTICS AFTER SWITCHING MODE

- The engine output characteristics when a mode is switched with the drive mode select switch is as follows.

Output characteristics of each mode

Engine output characteristics	Engine output
SPORT	Increase
STANDARD	Normal
ECO	Decrease
SNOW	Decrease (More reduction than ECO mode)

- After switching mode to a mode that engine output increase, engine output characteristics are changed after releasing the accelerator pedal.

ECO DRIVE INDICATOR LAMP CONTROL AND ECO PEDAL CONTROL

Refer to [EC-55, "Infiniti Drive Mode Selector : System Description"](#).

STEERING REACTION FORCE CHARACTERISTICS

- The steering reaction force characteristics when a mode is switched with the drive mode select switch is as follows.
- The steering characteristics is switched near the neutral position.

INTEGRAL SWITCH OPERATION

The Infiniti Drive Mode Selector cannot be operated until the start-up of the navigation system is completed.

PERSONAL MODE OPERATION

- The vehicle characteristics set by the driver cannot be achieved if PERSONAL is not selected by using the drive mode select switch.
- Any of the following operation allows saving of the vehicle characteristics if they are changed by the integral switch.
 - More than 10 seconds elapse after changing the vehicle characteristics.
 - Personal Mode Operation allows the driver to operate a back icon on the integral switch (lower display).
 - Press a MENU button on the integral switch (lower display).

Log-in Function

INFOID:000000011284384

- When the battery is removed/replaced, the Infiniti InTuition settings of the driver seat control unit and the combination meter is reset.
- When display control unit is replaced, all user registration information is reset and all the settings of Infiniti InTuition-related parts are erased.
- If the log-in function-related following units are replaced, user registration information of the replaced part is all reset.
 - Chassis control module
 - Driver seat control unit
 - Combination meter
 - A/C auto amp.
 - ADAS control unit
 - AV control unit
 - NAVI control unit
- If the battery voltage is 10 V or less, settings may not be saved.
- When the vehicle is operated or the ignition switch is turned OFF while changing the settings of log-in function, the change results may not be reflected. To reflect changes, turn OFF the ignition key or operate the vehicle after waiting for 10 seconds or returning to HOME.

BASIC INSPECTION

DIAGNOSIS AND REPAIR WORK FLOW

Infiniti Drive Mode Selector

Infiniti Drive Mode Selector : Work Flow

INFOID:000000011284385

OVERALL SEQUENCE

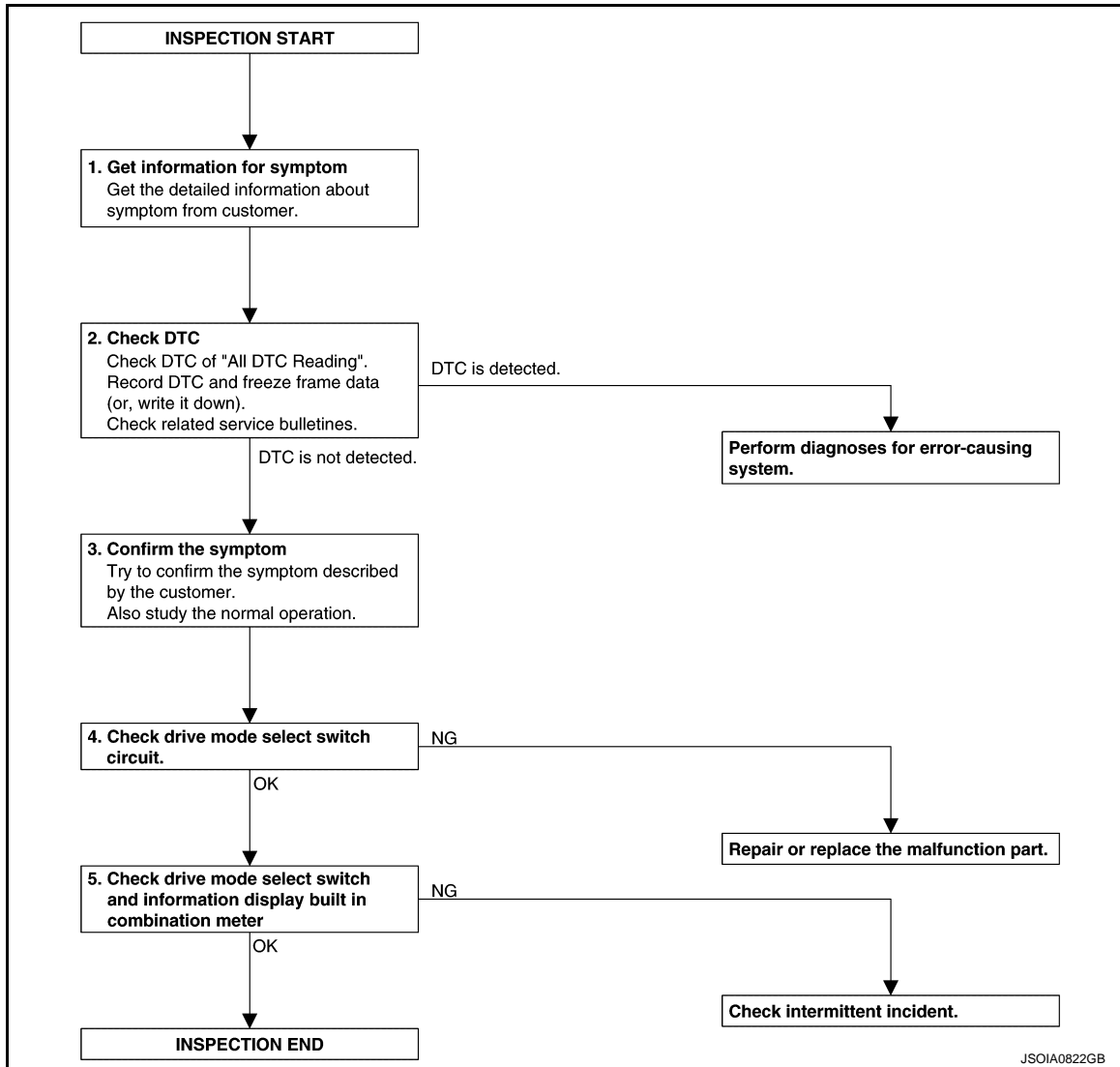

DETAILED FLOW

1.GET INFORMATION FOR SYMPTOM

Get the detailed information about symptom from customer.

>> GO TO 2.

2.CHECK DTC

1. Check DTC of "All DTC Reading" using CONSUL.
2. Perform the following procedure if DTC is displayed.
 - Record DTC and freeze frame data. (Or, write it down.)
3. Check related service bulletins for information.

Is any DTCs detected?

YES >> Perform the trouble diagnosis for DTC indicated.

A
B
C
D
E
F
G
H
I
J
K
L
M
N
P

DMS

DIAGNOSIS AND REPAIR WORK FLOW

[Infiniti InTuition]

< BASIC INSPECTION >

NO >> GO TO 3.

3. CONFIRM THE SYMPTOM

Try to confirm the symptom described by the customer.

Also study the normal operation related to the symptom. Refer to [DMS-16. "Infiniti Drive Mode Selector"](#).

>> GO TO 4.

4. CHECK DRIVE MODE SELECT SWITCH CIRCUIT

Check drive mode select switch circuit. Refer to [DMS-21. "Diagnosis Procedure"](#).

Is inspection result normal?

YES >> GO TO 5.

NO >> Repair or replace error-detected parts.

5. CHECK DRIVE MODE SELECT SWITCH AND METER INDICATION

1. Turn ignition switch OFF and wait at least 10 seconds.
2. Turn ignition switch ON.
3. Check that STANDARD is displayed on the information display screen of the combination meter.
4. Check that the view of information display changes as STANDARD ⇒ SPORT ⇒ PERSONAL when switching the drive mode select switch to up side.
5. Check that the view of information display changes as PERSONAL ⇒ SPORT ⇒ STANDARD ⇒ ECO ⇒ SNOW when switching the drive mode select switch to down side.

Is the inspection result normal?

YES >> INSPECTION END

NO >> Check intermittent incident. Refer to [GI-42. "Intermittent Incident"](#).

LOG-IN FUNCTION

DIAGNOSIS AND REPAIR WORK FLOW

< BASIC INSPECTION >

[Infiniti InTuition]

LOG-IN FUNCTION : Work Flow

INFOID:000000011284386

OVERALL SEQUENCE

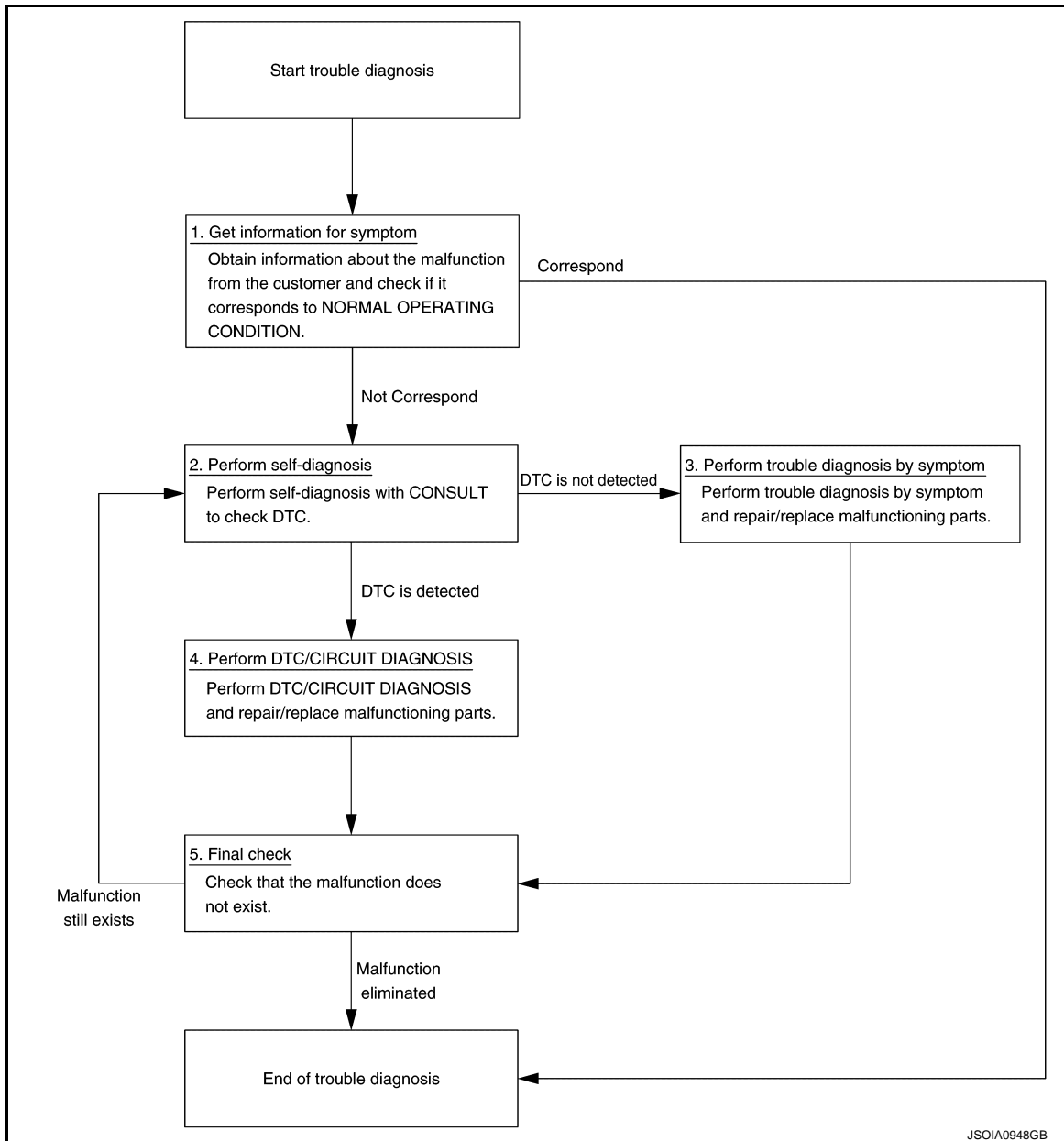

DETAILED FLOW

1. GET INFORMATION FOR SYMPTOM

Obtain information about the malfunction from the customer and check if it corresponds to NORMAL OPERATING CONDITION.

Does it correspond to NORMAL OPERATING CONDITION?

YES >> Explain to the customer that it is not a malfunction.

NO >> GO TO 2.

2. PERFORM SELF-DIAGNOSIS

With CONSULT
Perform self-diagnosis for "CHASSIS CONTROL".

Is DTC detected?

YES >> Record or print self-diagnosis results and freeze frame data (FFD). GO TO 4.

NO >> GO TO 3.

JSOIA0948GB

A
B
C
D
E
F
G
H
I
J
K
L
M
N

DMS

P

DIAGNOSIS AND REPAIR WORK FLOW

< BASIC INSPECTION >

[Infiniti InTuition]

3.PERFORM TROUBLE DIAGNOSIS BY SYMPTOM

Perform trouble diagnosis by symptom and repair/replace malfunctioning parts.

>> GO TO 5.

4.PERFORM DTC/CIRCUIT DIAGNOSIS

Perform DTC/CIRCUIT DIAGNOSIS and repair/replace malfunctioning parts.

>> GO TO 5.

5.FINAL CHECK

Recheck the symptom and check that symptom is not reproduced on the same conditions.

Is the symptom reproduced?

YES >> GO TO 2.

NO >> INSPECTION END

DTC/CIRCUIT DIAGNOSIS

DRIVE MODE SELECT SWITCH CIRCUIT

Diagnosis Procedure

INFOID:0000000011284387

1. CHECK DRIVE MODE SELECT SWITCH SIGNAL CIRCUIT

1. Turn ignition switch OFF.
2. Disconnect drive mode select switch harness connector and chassis control module harness connector.
3. Check the continuity between drive mode select switch harness connector and chassis control module harness connector.

+		-		Continuity
Drive mode select switch		Chassis control module		
Connector	Terminal	Connector	Terminal	
M35	2	E22	6	Existed
	3		5	

4. Also check harness for short to ground and to power.

Is the inspection result normal?

YES >> GO TO 2.

NO >> Repair or replace error-detected parts.

2. CHECK DRIVE MODE SELECT SWITCH GROUND CIRCUIT

Check the continuity between drive mode select switch harness connector and ground.

+		-	Continuity
Drive mode select switch			
Connector	Terminal		
M35	1	Ground	Existed

Is the inspection result normal?

YES >> GO TO 3.

NO >> Repair or replace error-detected parts.

3. CHECK DRIVE MODE SELECT SWITCH

Check drive mode select switch. Refer to [DMS-21. "Component Inspection \(Drive Mode Select Switch\)".](#)

Is the inspection result normal?

YES >> INSPECTION END

NO >> Replace drive mode switch. Refer to [DMS-25. "Removal and Installation".](#)

Component Inspection (Drive Mode Select Switch)

INFOID:0000000011284388

1. CHECK DRIVE MODE SELECT SWITCH

1. Turn ignition switch OFF.
2. Disconnect drive mode select switch harness connector.
3. Check the continuity between drive mode select switch terminals as follows.

DMS

DRIVE MODE SELECT SWITCH CIRCUIT

< DTC/CIRCUIT DIAGNOSIS >

[Infiniti InTuition]

Drive mode select switch		Condition	Continuity
+	-		
Terminals			
1	2	Switch to down-position.	Existed
		Other than the above.	Not existed
	3	Switch to up-position.	Existed
		Other than the above.	Not existed

Is the inspection result normal?

YES >> INSPECTION END

NO >> Replace drive mode select switch. Refer to [DMS-25. "Removal and Installation"](#).

USER RECOGNITION OF LOG-IN FUNCTION IS NOT PERFORMED

< SYMPTOM DIAGNOSIS >

[Infiniti InTuition]

SYMPTOM DIAGNOSIS

USER RECOGNITION OF LOG-IN FUNCTION IS NOT PERFORMED

Description

INFOID:0000000011284389

User recognition of the log-in function is not performed in synchronization with the intelligent Key.

Diagnosis Procedure

INFOID:0000000011284390

1. CHECK SETTINGS

Check if the Intelligent Key link setting is ON.

Is the Intelligent Key link setting ON?

YES >> Perform trouble diagnosis for Intelligent Key. Refer to [DLK-146. "Diagnosis Procedure"](#).

NO >> Set the Intelligent Key link setting to ON.

A
B
C
D
E
F
G
H
I
J
K
L
M
N
P

DMS

NORMAL OPERATING CONDITION

< SYMPTOM DIAGNOSIS >

[Infiniti InTuition]

NORMAL OPERATING CONDITION

LOG-IN FUNCTION

LOG-IN FUNCTION : Description

INFOID:000000011284391

Symptom	Probable cause	Action
A function interlocked with the key does not work according to driver's settings.	Driver's settings is changed by other users.	Reconfigure and check operation.
The key link function does not work.	The key link function is deactivated.	Activate the key link function.
Set values of automatic drive positioner and combination meter are not stored.	Set values of automatic drive positioner and combination meter are erased when battery power supply is shut off.	When disconnecting battery, notify the customer that set values of automatic drive positioner and combination meter are erased.
Not changed to a set position of automatic drive positioner.	If a seat position is changed manually before starting the AV system, then automatic adjustment to a set value is not performed.	This is not a malfunction.
	The key link function is deactivated.	Activate the key link function.
Air conditioner does not work according to driver's settings.	<ul style="list-style-type: none"> • When ambient temperature is 0°C (32°F) or less, A/C switch is not operational because of preventing the windows from fogging up. • When the defroster switch is ON, the mode cannot be switched to DUAL mode. 	This is not a malfunction.
The welcome screen is not displayed.	The key link function is deactivated.	Activate the key link function.
	The showing of the welcome screen is disabled.	Enable the showing of the welcome screen.
A user other than the driver is shown on the welcome screen.	<ul style="list-style-type: none"> • The door is unlocked by without using driver's key. • Two or more keys are in the vehicle. 	If two or more keys are in the vehicle, the system may be misidentified. Select user from User list or turn OFF the key switch to unlock the door with driver-owned key.
User icons of other users are not displayed on the welcome screen.	No users except for guest are registered.	Perform user registration.
"You can store setting values for each user with a connected key" is shown on the display screen.	For a key newly identified by the system, a message of user setting is displayed.	If the user has a history of user registration with a different key, press the "Select User" button. For new registration, press the "Add User" button to perform the user registration.
User registration cannot be performed on the welcome screen.	This is not a malfunction. The user selection screen is displayed for approximately 5 seconds after the end of AV system startup.	After starting the integral switch (lower display), select user by pressing the user icon or User Edit.
"I-Key is turned off. To turn it on, turn on the I-Key link in the settings" is shown on the display screen.	The key link function is deactivated.	Activate the key link function.
Infiniti drive mode selector does not work according to driver's settings.	When the key switch is turned ON from the OFF condition, the STANDARD mode starts according to the specification.	Switch the mode to the PERSONAL mode interlocked with the log-in function.

REMOVAL AND INSTALLATION

DRIVE MODE SELECT SWITCH

Removal and Installation

INFOID:000000011284392

CAUTION:

Use waste to protect parts potential to interfere from being scratched.

REMOVAL

1. Remove center console side finisher LH and center console side finisher RH. Refer to [IP-23, "Exploded View"](#).
2. Remove cup holder assembly. Refer to [IP-23, "Exploded View"](#).
3. Remove fixing screw, and then remove finisher ①.
4. Disconnect harness connector from drive mode select switch.
5. Remove drive mode select switch fixing screw, and then remove drive mode select switch.

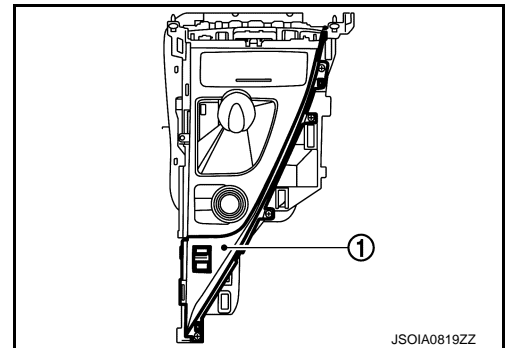

JSOIA0819ZZ

INSTALLATION

Install in the reverse order of removal.

A
B
C
D
E
F
G
H
I
J
K
L
M
N
P

DMS